

Tous droits strictement réservés. Reproduction ou communication o des liers interdite sous quelque forme que ce soit sans autorisation écrite du propriétaire. Propriete de c FCI. Droits de reproduction FCI.

All rights strictly reserved. Reproduction or issue to third parties in any form whatever is not permitted without written authority from the proprietor. Property of FCI. Copyright FCI.

**FCI**

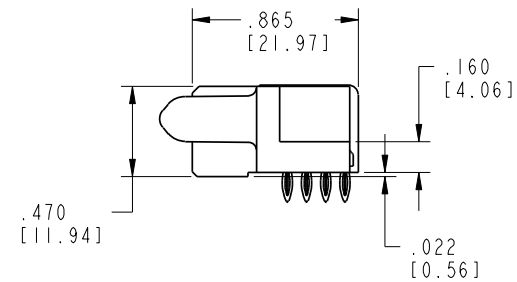
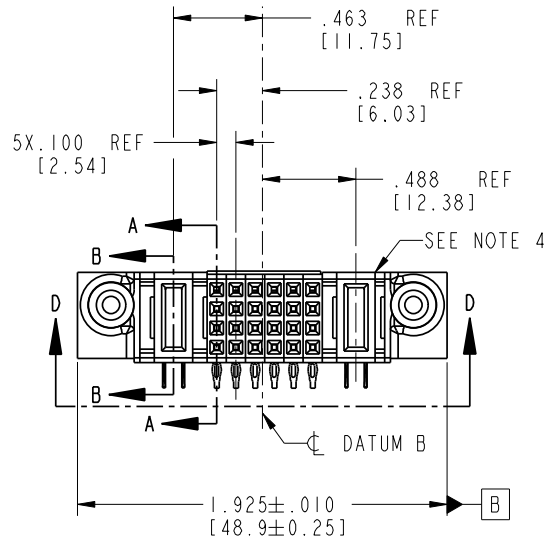
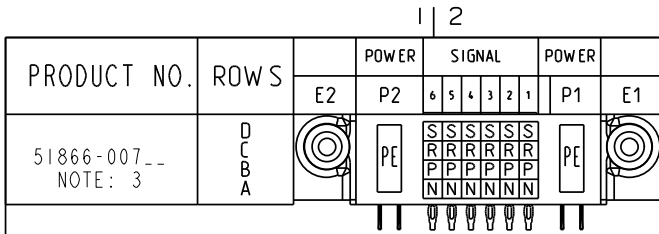

| CODE | DIM "M" MATING LENGTH | CONTACT TYPE |
|------|-----------------------|--------------|
| N    | N/A [N/A]             | SIGNAL       |
| P    | N/A [N/A]             | SIGNAL       |
| R    | N/A [N/A]             | SIGNAL       |
| S    | N/A [N/A]             | SIGNAL       |
| PE   | .042 [1.07]           | POWER        |

|             |                |       |          |            |                        |                                       |             |              |                       |                        |  |
|-------------|----------------|-------|----------|------------|------------------------|---------------------------------------|-------------|--------------|-----------------------|------------------------|--|
| mat'l code  |                |       |          | SEE NOTE 2 |                        | tolerances unless otherwise specified |             | CUSTOMER     |                       | <br>www.fciconnect.com |  |
| lir         | ecn no.        | dr    | date     | linear     | .XX±.01/0.X±0.3        |                                       | COPY        |              | title                 |                        |  |
| A           | V12545         | JWS   | 11/29/01 |            | .XXX±.005/0.XX±0.13    |                                       | projection  |              | IP + 24S + IP         |                        |  |
| B           | DG05-0530      | GuoJM | 12/09/05 | angles     | .XXX±.0020/0.XXX±0.051 |                                       | <br>INCH/MM |              | R/A PRESS FIT RECEPT. |                        |  |
|             |                |       |          | dr         | 0° ± 2°                |                                       | scale       |              | product family        |                        |  |
|             |                |       |          | enrg       | J. SHAFFER 11/29/01    |                                       | 1:1         |              | PwrBlade              |                        |  |
|             |                |       |          | chr        | J. ALLISON 11/29/01    |                                       | size        |              | code                  |                        |  |
|             |                |       |          | oppd       | J. ALLISON 11/29/01    |                                       | dwg no      |              | 213                   |                        |  |
| sheet index | revision sheet | B 1   | B 2      | B 3        | B 4                    | A 51866-007                           |             | sheet 1 of 4 |                       |                        |  |

Pro/E

**PDM: Rev: B**

STATUS: **Released**

Printed: Oct 08, 2006

Tous droits strictement réservés. Reproduction ou communication a des tiers interdite sous quelque forme que ce soit sans autorisation écrite du propriétaire. Propriété de c FCI. Droits de reproduction FCI.

All rights strictly reserved. Reproduction or issue to third parties in any form whatever is not permitted without written authority from the proprietor. Property of FCI. Copyright FCI.

**FCI**

PRODUCT NUMBER

51866-007\_\_  
NOTE: 3

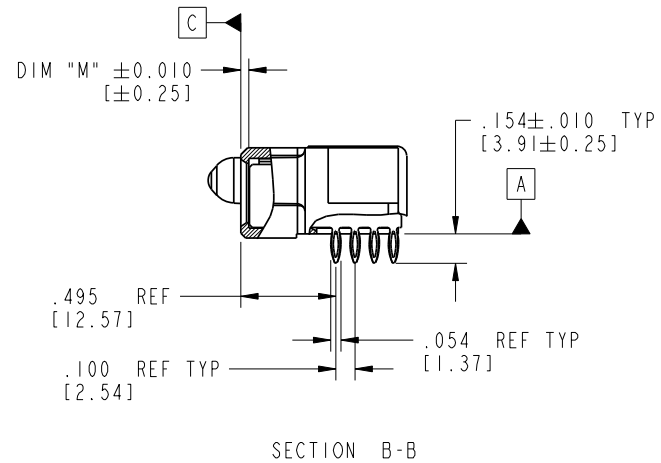
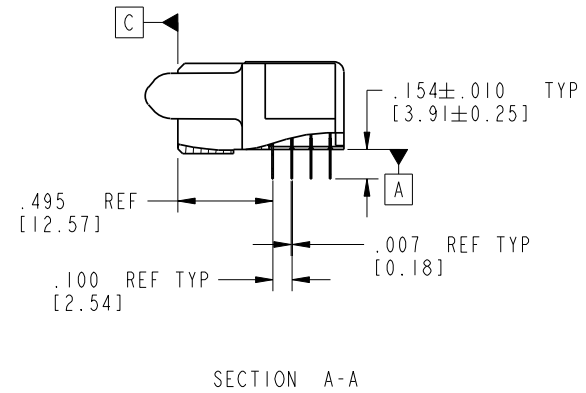
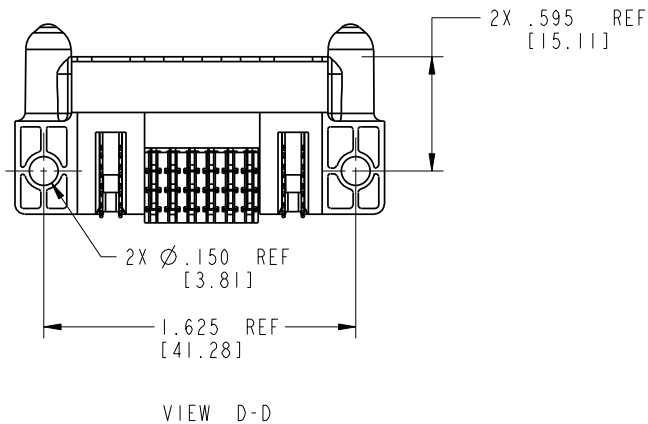

|             |                |            |      |                                       |                        |            |                |            |                       |                    |  |
|-------------|----------------|------------|------|---------------------------------------|------------------------|------------|----------------|------------|-----------------------|--------------------|--|
| mat'l code  |                | SEE NOTE 2 |      | tolerances unless otherwise specified |                        | CUSTOMER   |                | <b>FCI</b> |                       | www.fciconnect.com |  |
| lir         | ecn no.        | dr         | date | linear                                | .XX±.01/0.X±0.3        | projection | COPY           |            | title                 |                    |  |
| B           |                |            |      |                                       | .XX±.005/0.XX±0.13     | INCH/MM    | IP + 24S + IP  |            | R/A PRESS FIT RECEPT. |                    |  |
|             |                |            |      | angles                                | .XXX±.0020/0.XXX±0.051 | scale      | product family |            | code                  |                    |  |
|             |                |            |      | dr                                    | 0°±2°                  | 1:1        | PwrBlade       |            | 213                   |                    |  |
|             |                |            |      | engr                                  | J. SHAFFER 11/29/01    |            | size           |            | sheet                 |                    |  |
|             |                |            |      | chr                                   | J. ALLISON 11/29/01    |            | A              |            | 2 of 4                |                    |  |
|             |                |            |      | appd                                  | J. ALLISON 11/29/01    |            | 51866-007      |            |                       |                    |  |
| sheet index | revision sheet |            |      |                                       |                        |            |                |            |                       |                    |  |

Pro/E

**PDM: Rev: B**

STATUS: **Released**

Printed: Oct 08, 2006

Tous droits strictement réservés. Reproduction ou communication o des liers interdite sous quelque forme que ce soit sans autorisation écrite du propriétaire. Propriete de c FCI. Droits de reproduction FCI.

**FCI**

All rights strictly reserved. Reproduction or issue to third parties in any form whatever is not permitted without written authority from the proprietor. Property of FCI. Copyright FCI.

PRODUCT NUMBER  
51866-007\_\_  
NOTE: 3

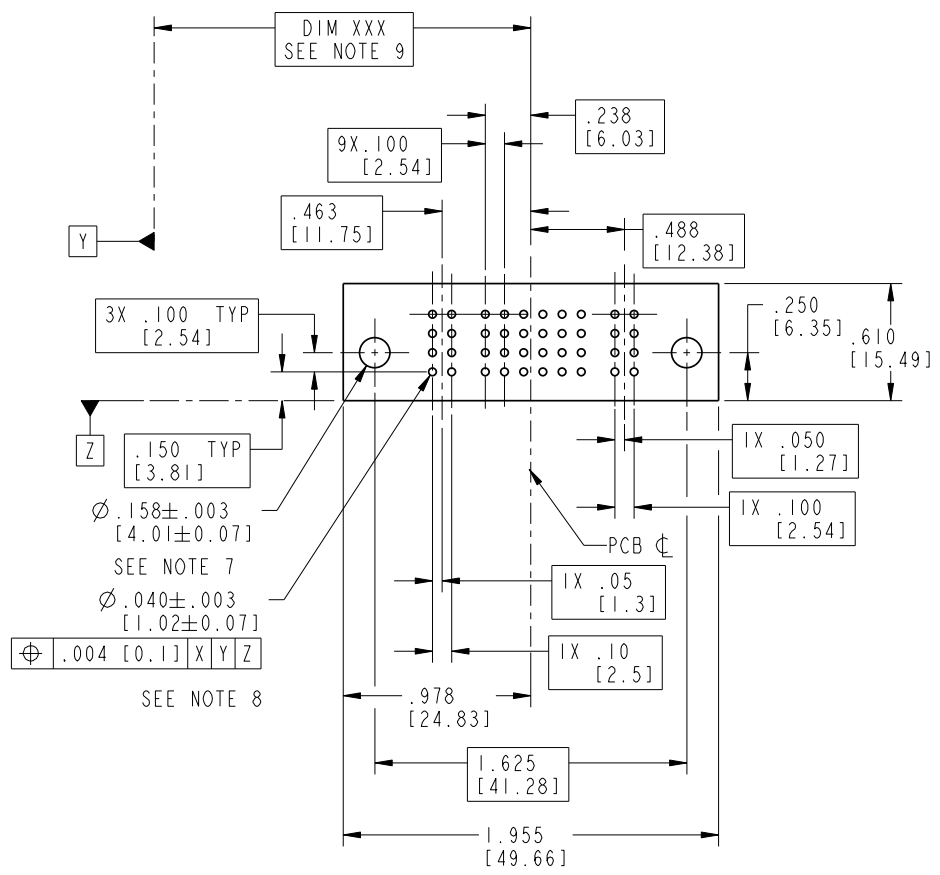

|             |                |            |      |                                       |                        |            |                |            |                       |                    |      |
|-------------|----------------|------------|------|---------------------------------------|------------------------|------------|----------------|------------|-----------------------|--------------------|------|
| mat'l code  |                | SEE NOTE 2 |      | tolerances unless otherwise specified |                        | CUSTOMER   |                | <b>FCI</b> |                       | www.fciconnect.com |      |
| lir         | ecn no.        | dr         | date | linear                                | .XX±.01/0.X±0.3        | projection | COPY           |            | title                 |                    |      |
| B           |                |            |      | linear                                | .XXX±.005/0.XX±0.13    |            |                |            | IP + 24S + IP         |                    |      |
|             |                |            |      | angles                                | .XXX±.0020/0.XXX±0.051 |            |                |            | R/A PRESS FIT RECEPT. |                    |      |
|             |                |            |      | angles                                | 0°±2°                  |            | product family |            | PwrBlade              |                    | code |
|             |                |            |      | dr                                    | J. SHAFFER 11/29/01    |            | size           |            | A                     |                    | 213  |
|             |                |            |      | enrg                                  | J. ALLISON 11/29/01    | scale      |                | 51866-007  |                       | sheet              |      |
|             |                |            |      | chr                                   | J. ALLISON 11/29/01    | 1:1        |                |            |                       | 3 of 4             |      |
|             |                |            |      | appd                                  | J. ALLISON 11/29/01    |            |                |            |                       |                    |      |
| sheet index | revision sheet |            |      |                                       |                        |            |                |            |                       |                    |      |

1 | 2

Pro/E

**PDM: Rev: B**

STATUS: **Released**

Printed: Oct 08, 2006

1 | 2

3 |

4

A

A

B

B

PRODUCT NUMBER

51866-007\_\_  
NOTE: 3

NOTES:

1. DIMENSIONS AND TOLERANCES ARE IN ACCORDANCE WITH ASME Y14.5M, 1994 UNLESS OTHERWISE SPECIFIED.

CONNECTORS NOTES:

2. HOUSING MATERIAL: UL 94 V-0 GLASS FILLED HIGH TEMP THERMO PLASTIC  
POWER CONTACT MATERIAL: COPPER ALLOY  
SIGNAL PIN MATERIAL: COPPER ALLOY

3. PLATING:

51866-007 Singal Pin:30u"/0.76um Au OVER 50u"/1.27um Ni ON THE CONTACT AREA.  
AND 100u"/2.54um SnPb PLATING OVER 50u"/1.27um Ni ON THE TERMINATION SECTION.  
Power Pin:30u"/0.76um Au OVER 50u"/1.27um Ni ON THE CONTACT AREA,  
AND 100u"/2.54um SnPb PLATING OVER 50u"/1.27um Ni ON THE TERMINATION SECTION.  
  
51866-007LF Singal Pin:30u"/0.76um Au OVER 50u"/1.27um Ni ON THE CONTACT AREA.  
AND 78u"/2.00um Sn PLATING OVER 50u"/1.27um Ni ON THE TERMINATION SECTION.  
Power Pin:30u"/0.76um Au OVER 50u"/1.27um Ni ON THE CONTACT AREA,  
AND 78u"/2.00um Sn PLATING OVER 50u"/1.27um Ni ON THE TERMINATION SECTION.

PART NUMBER 51866-007LF MEETS EUROPEAN UNION DIRECTIVE AND OTHER ICOUNTRY REGULATIONS AS DESCRIBED IN GS-22-008.

THE HOUSING WILL WITHSTAND EXPOSURE TO 260° PEAK TEMPERATURE FOR 10 SECONDS IN A WAVE SOLDER APPLICATION WITH A CIRCUIT BOARD.

4. "MANUFACTURER" NAME, P/N, AND DATE CODE TO APPEAR ON THIS SURFACE.

5. PRODUCT SPECIFICATION GS-12-149.

PCB - NOTES:

- 6. ALL HOLE DIAMETERS ARE FINISHED HOLE SIZE.
- 7. HOLD DOWN THROUGH HOLES ARE UNPLATED.
- 8. Ø.0453±0.0010 [1.151±0.025] DRILLED HOLES PLATED WITH 0.0003 [0.008] MIN SnPb OVER .001 [0.03] TO .003 [0.08] Cu PLATING TO ACHIEVE Ø.040±.003 [1.02±.07] HOLE.
- 9. "DIM XXX" TO BE DETERMINED BY THE CUSTOMER.

10. USE FCI CAM TOOL 430140-XXX TO APPLY CONNECTOR TO PCB.

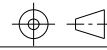
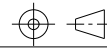
|             |                |            |      |                                       |                        |          |  |   |        |
|-------------|----------------|------------|------|---------------------------------------|------------------------|----------|--|---|--------|
| mat'l code  |                | SEE NOTE 2 |      | tolerances unless otherwise specified |                        | CUSTOMER |  | <br>www.fciconnect.com |        |
| lir         | ecn no.        | dr         | date | linear                                | .XX±.01/0.X±0.3        |          | projection   | COPY  |        |
| B           |                |            |      |                                       | .XXX±.005/0.XX±0.13    |          |  | <br>INCH/MM            | title  |
|             |                |            |      | angles                                | .XXX±.0020/0.XXX±0.051 |          | <br>R/A PRESS FIT RECEPT. |   |        |
|             |                |            |      |                                       | 0° ± 2°                |          | product family   |   | code   |
|             |                |            |      | dr                                    | J. SHAFFER             | 11/29/01 | PwrBlade   |   | 213    |
|             |                |            |      | enrg                                  | J. ALLISON             | 11/29/01 | size   | dwg no  | sheet  |
|             |                |            |      | chr                                   | J. ALLISON             | 11/29/01 | A  | 51866-007   | 4 of 4 |
|             |                |            |      | appd                                  | J. ALLISON             | 11/29/01 | scale  |   |        |
|             |                |            |      |                                       |                        |          | 1:1  |   |        |
| sheet index | revision sheet |            |      |                                       |                        |          |  |   |        |

Tous droits strictement reserves. Reproduction ou communication a des tiers interdite sous quelque forme que ce soit sans autorisation ecrite du proprietaire. Propriete de c FCI. Droits de reproduction FCI.



All rights strictly reserved. Reproduction or issue to third parties in any form whatever is not permitted without written authority from the proprietor. Property of FCI. Copyright FCI.